

KHADASS

Something a little different.

Shenzhen Wesion Technology Co., Ltd.			
<b>Project:</b>	VIM4		
<b>File:</b>	14 Khadas		
<b>Date:</b>	Thursday, April 07, 2022	<b>Rev:</b>	V12
<b>Designed_by:</b>	Totti	<b>Sheet:</b>	0

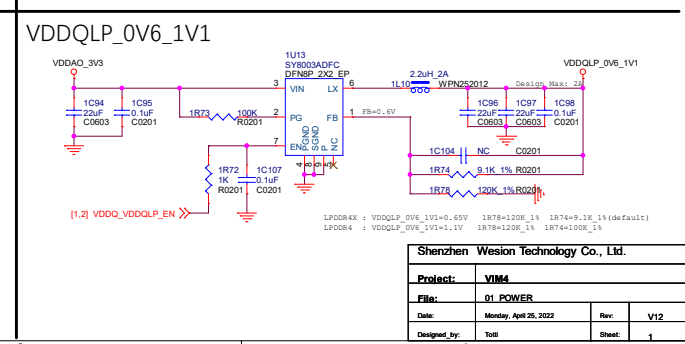

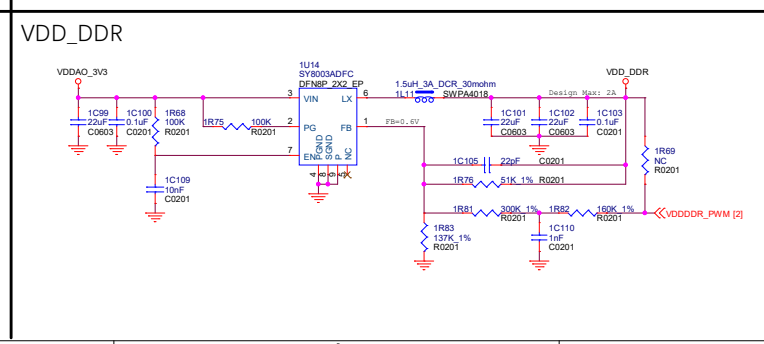
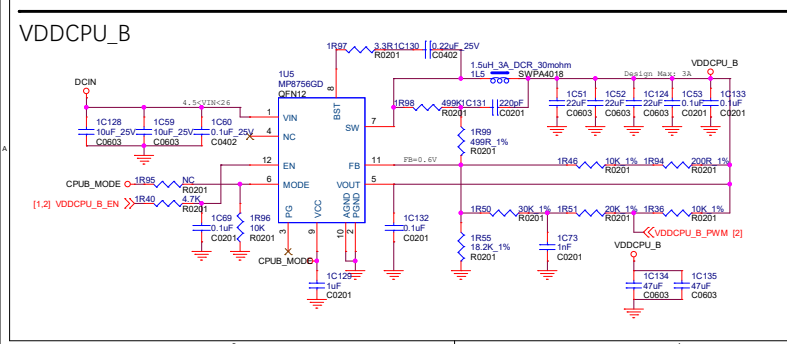
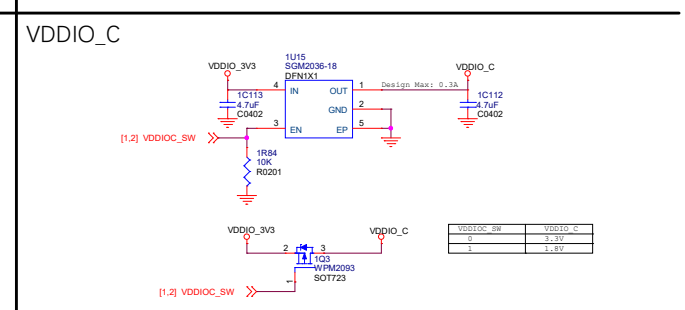
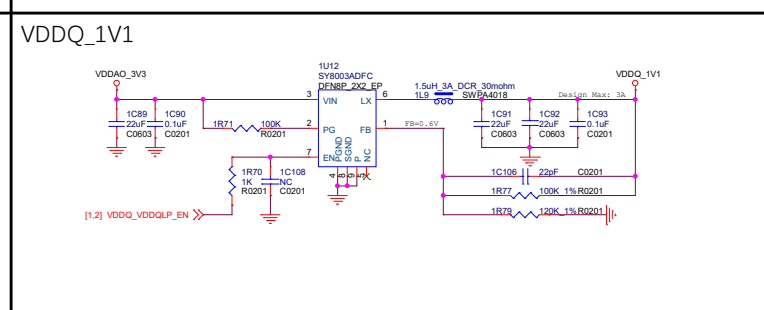
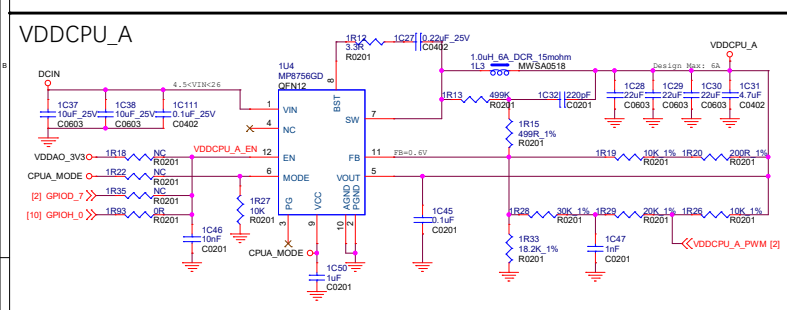
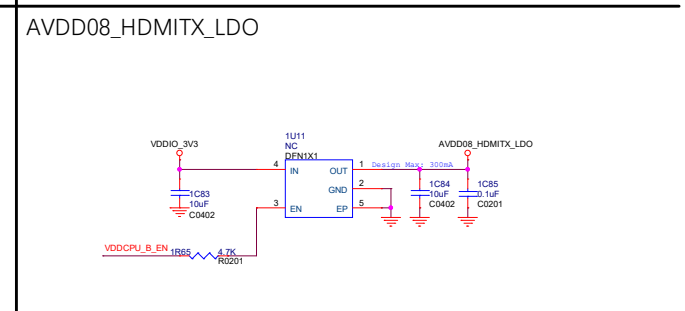
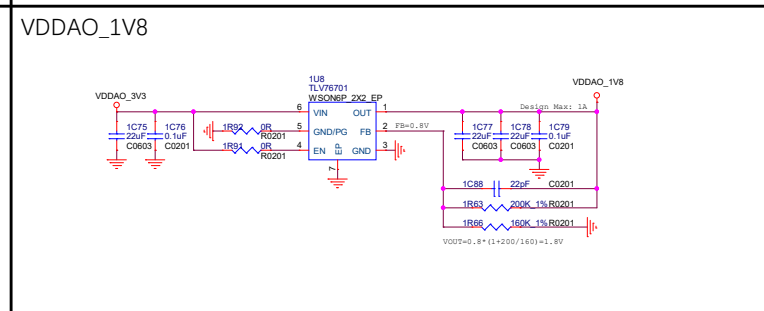
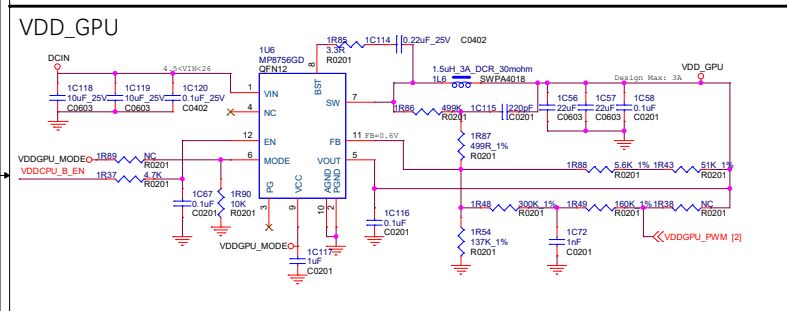
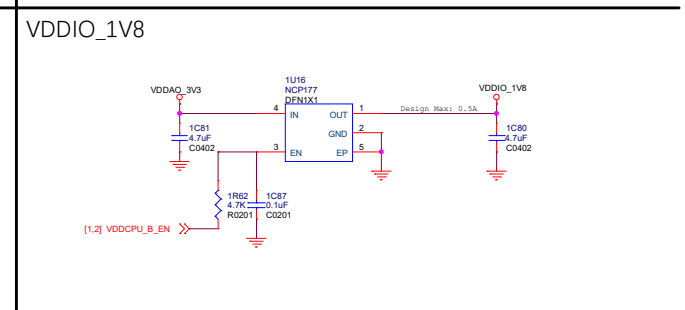
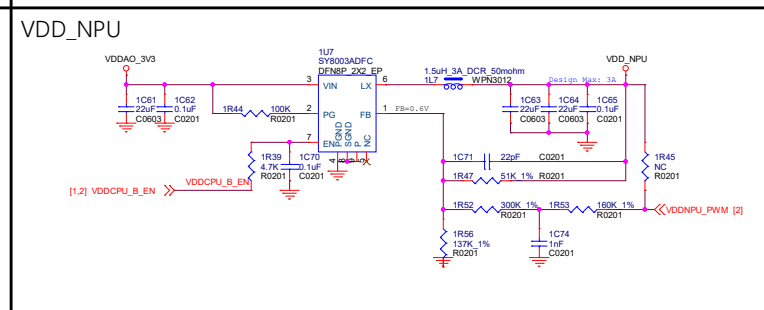
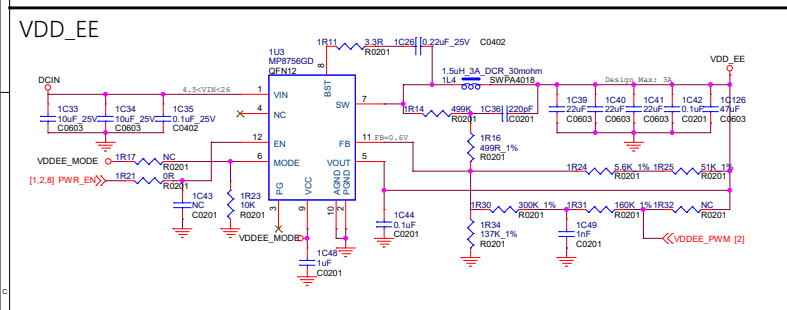
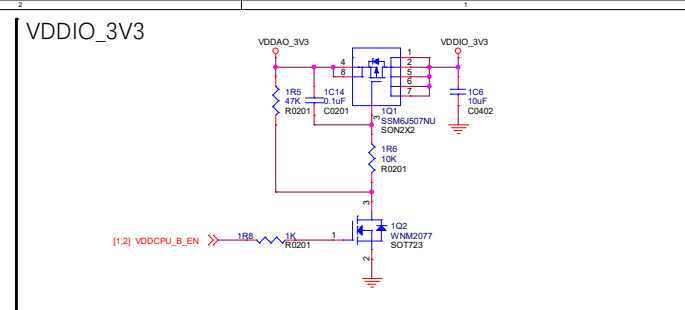
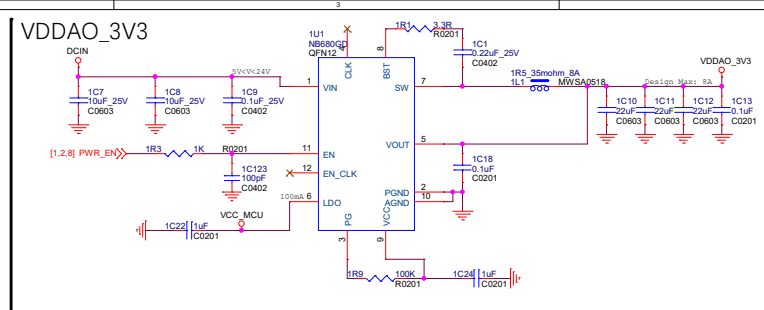
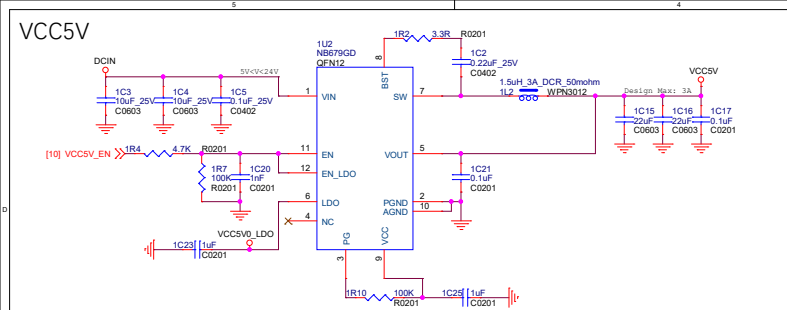
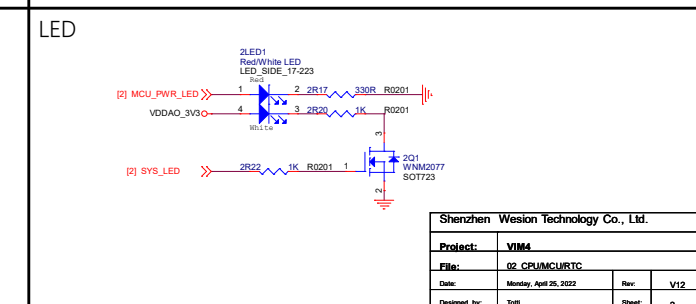
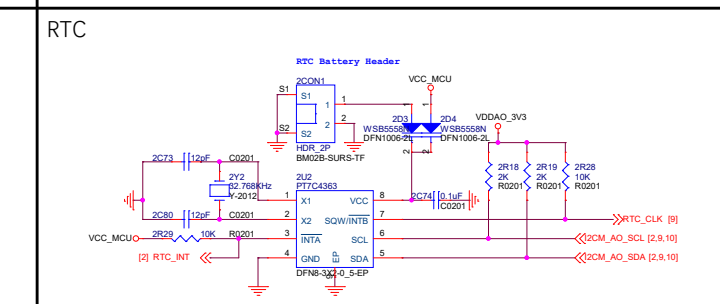
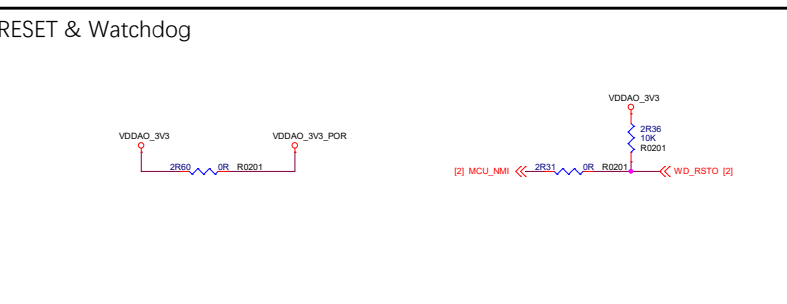
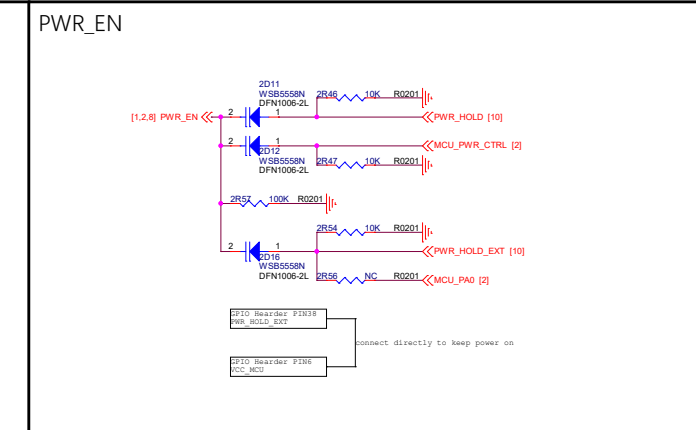
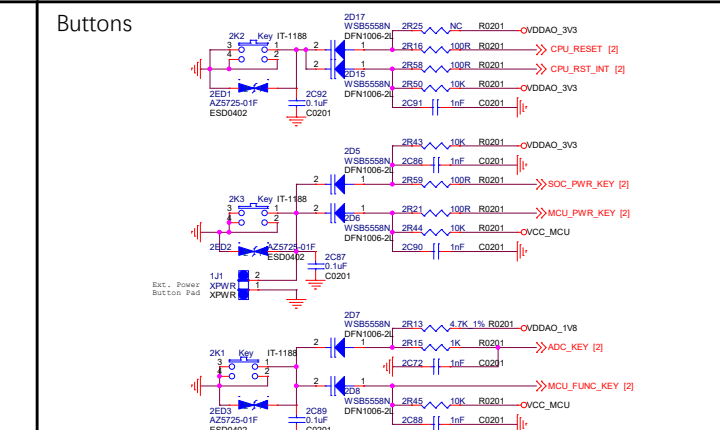
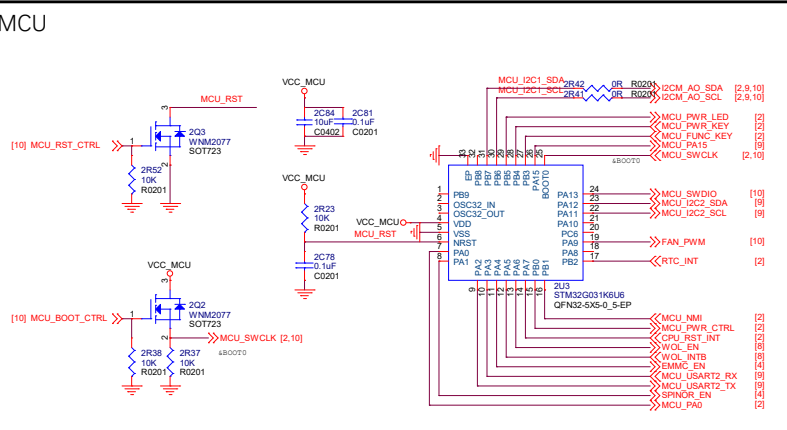
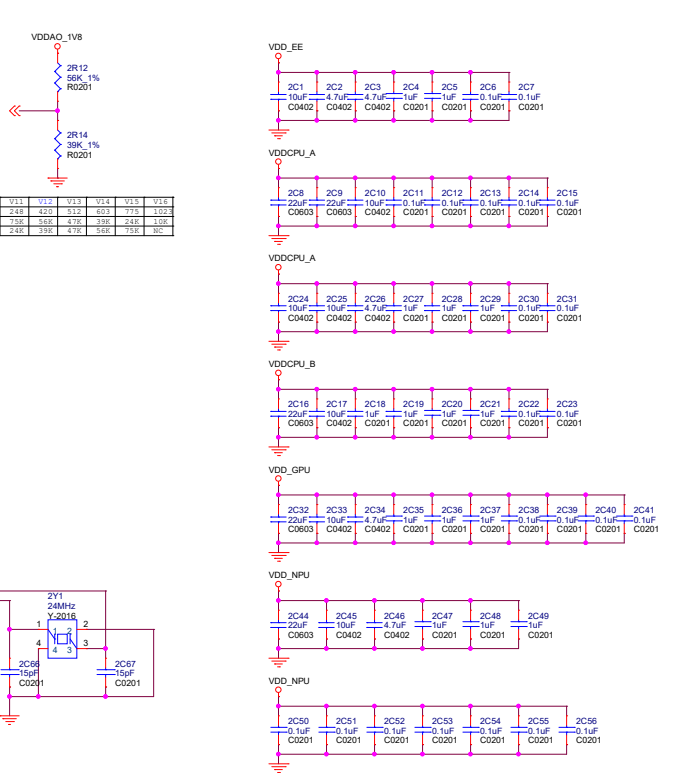
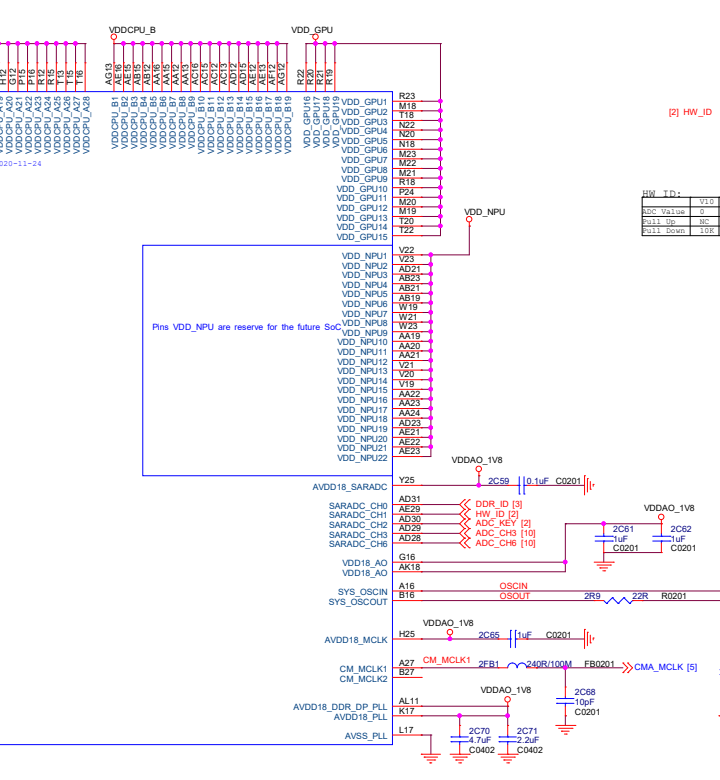
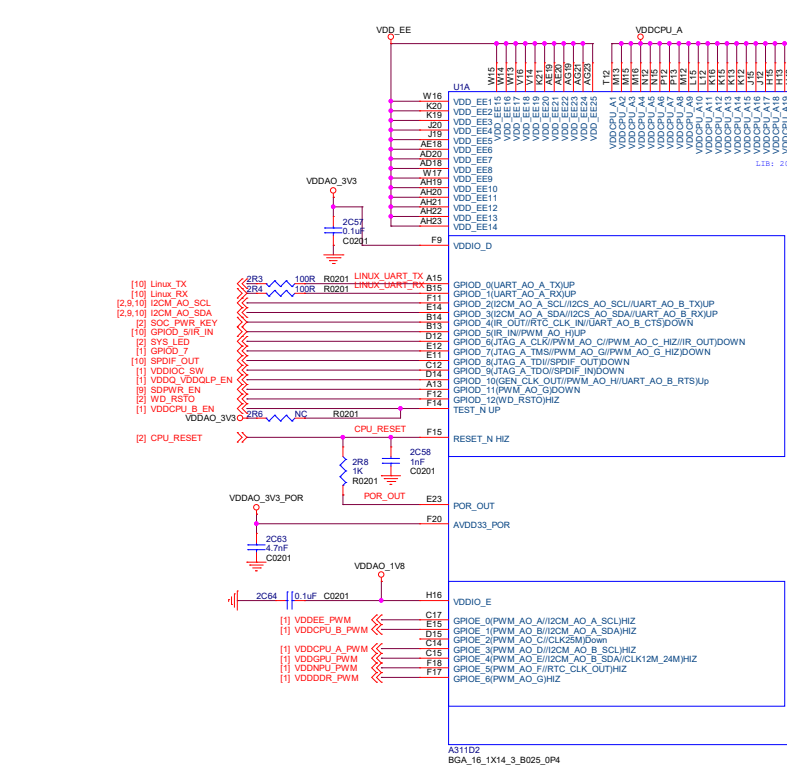

Shenzhen Weson Technology Co., Ltd.			
Project:	VIMS4	Rev:	V12
File:	02_CPU/MCUTCRC	Date:	Monday, April 25, 2022
Designed_by:	TSL	Checked:	2

DDR Channel 0

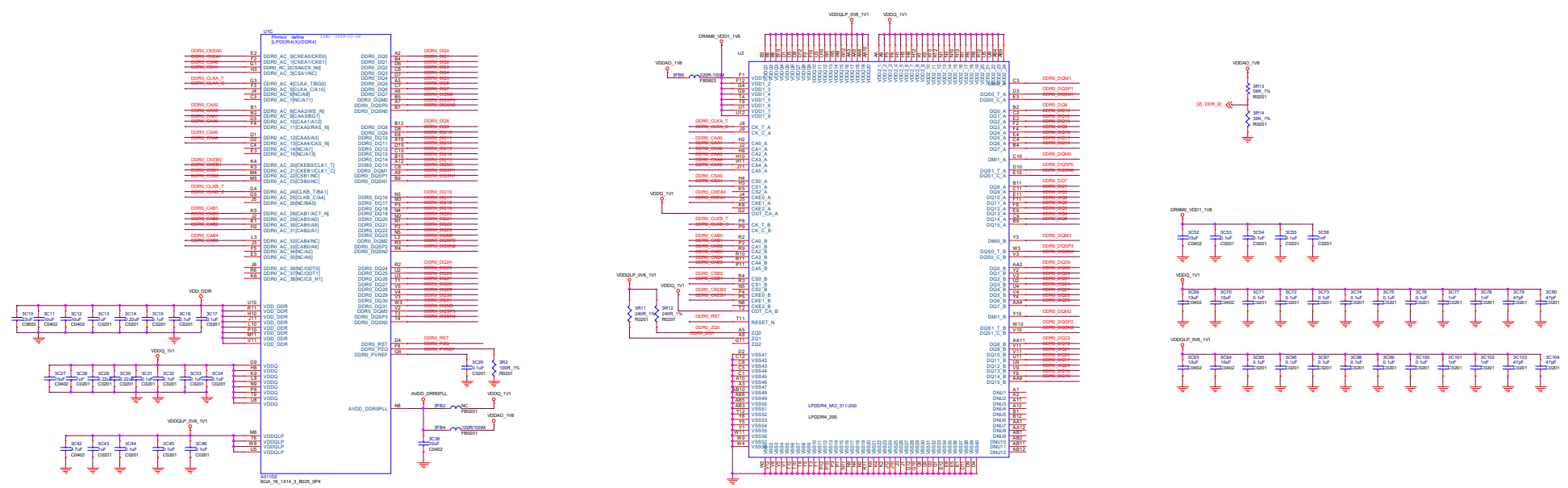

DDR Channel 1

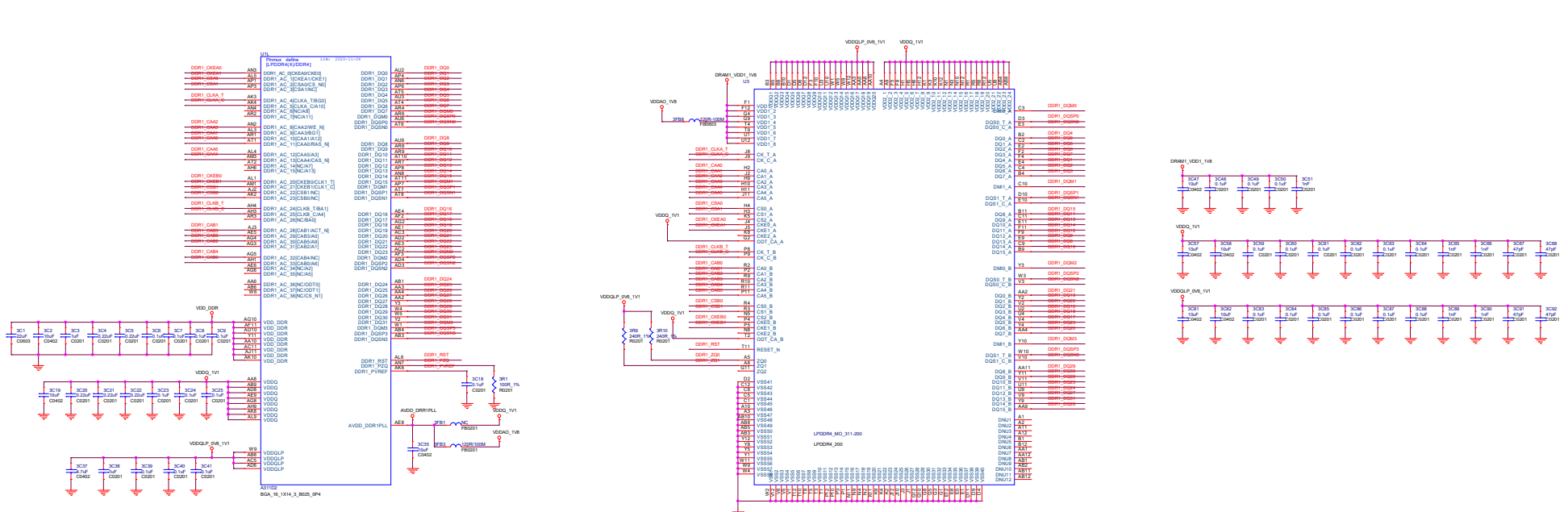

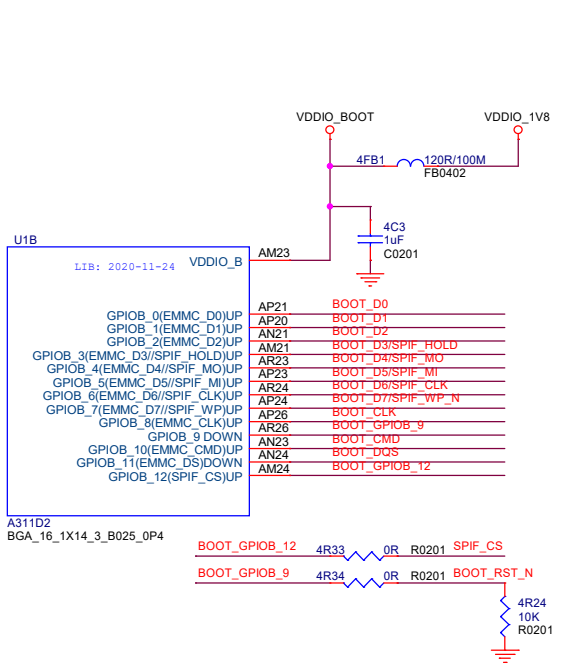

### EMMC

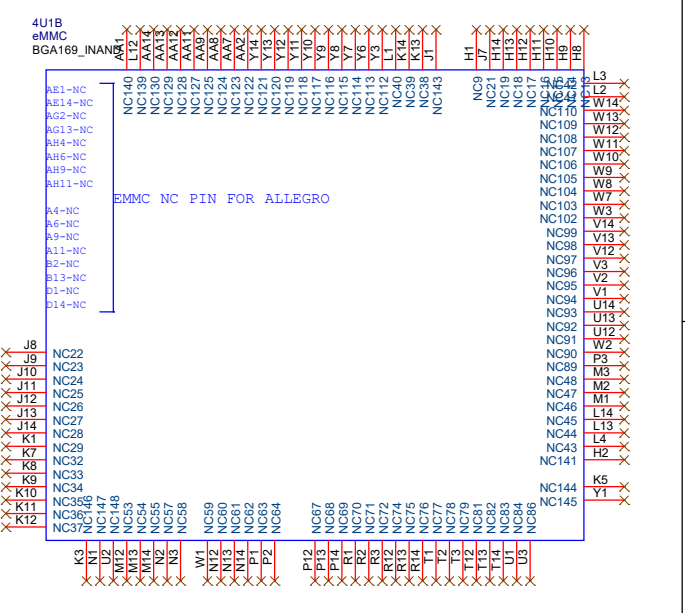
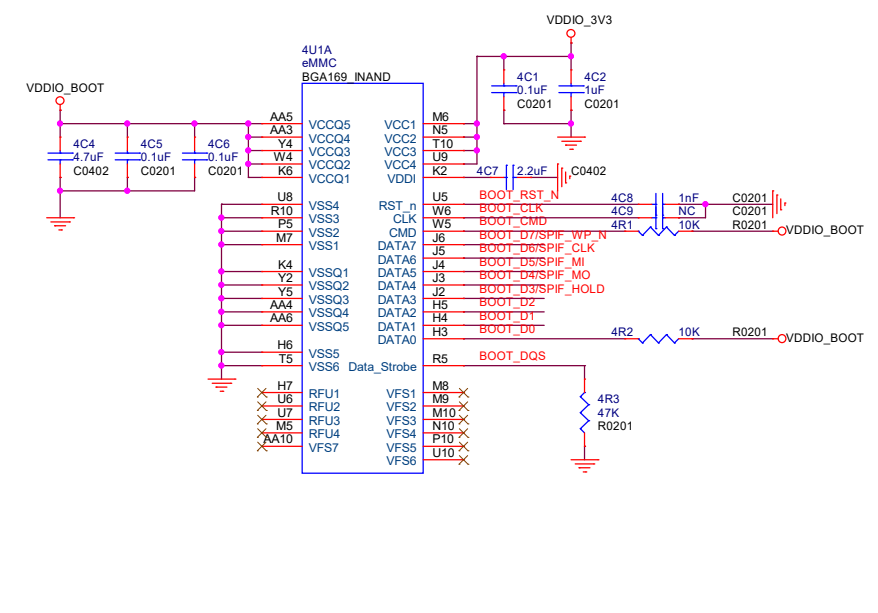

### Power ON Config

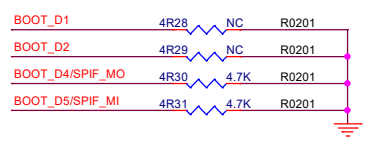

### SPI Flash

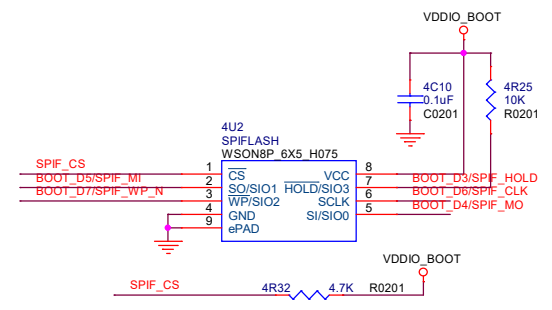

### TST

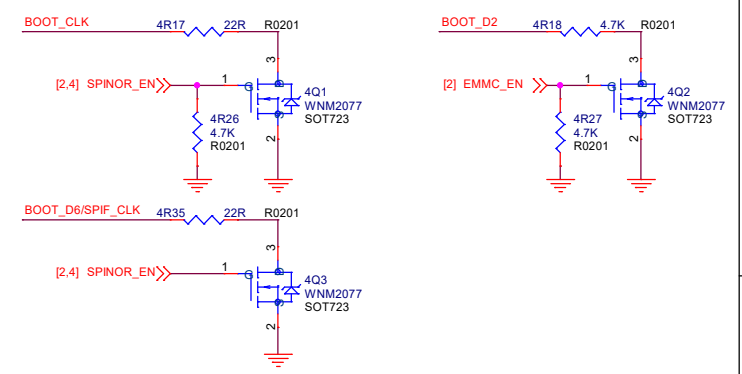

Booting Sequence Diagram

EMMC EN	SPINOR EN	1st Boot	2nd Boot	3rd Boot	4th Boot
0	0	SD Card	eMMC	SPI Flash	USB
1	0	SD Card	SPI Flash	eMMC	USB
x	1	USB	SPI Flash	eMMC	USB

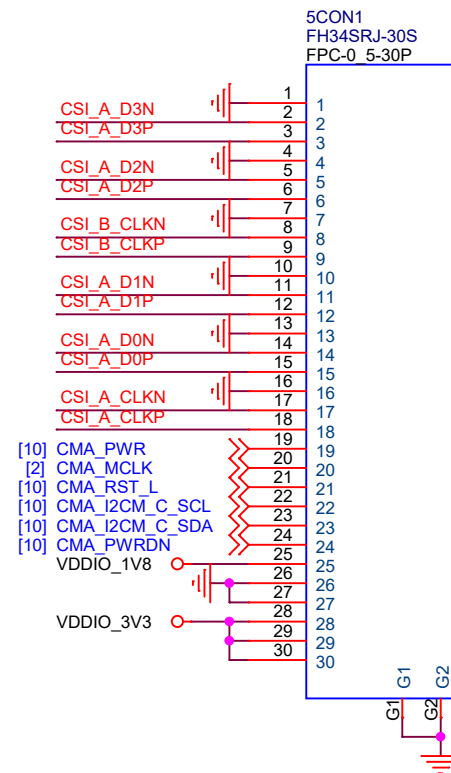
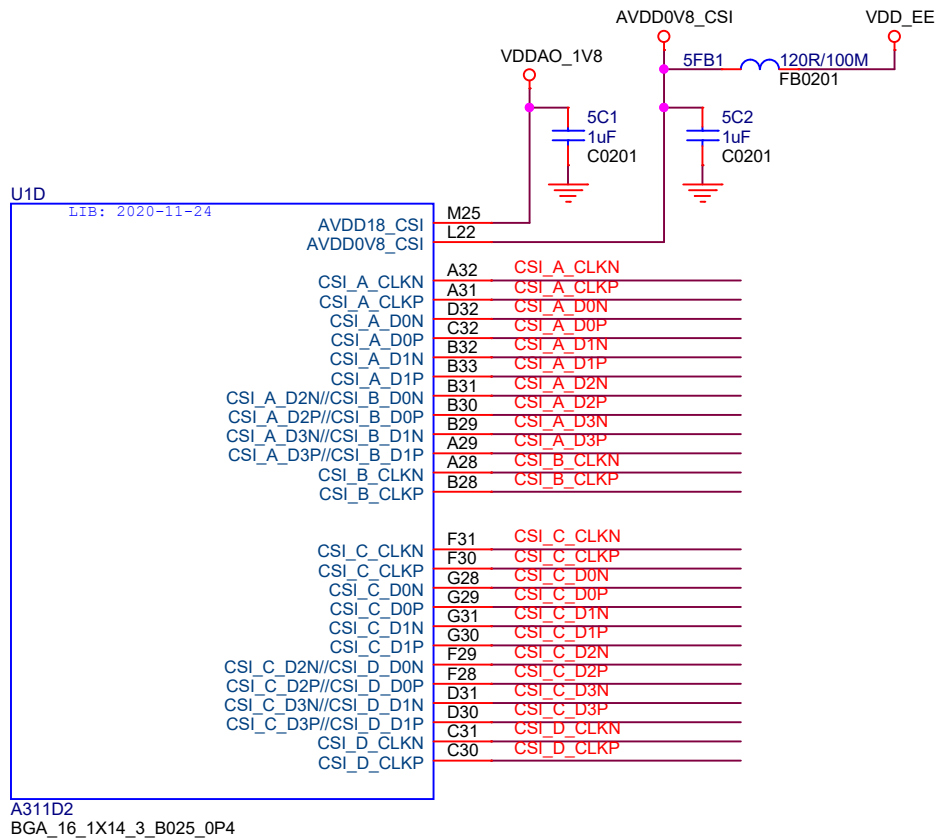

MIPI-CSI1

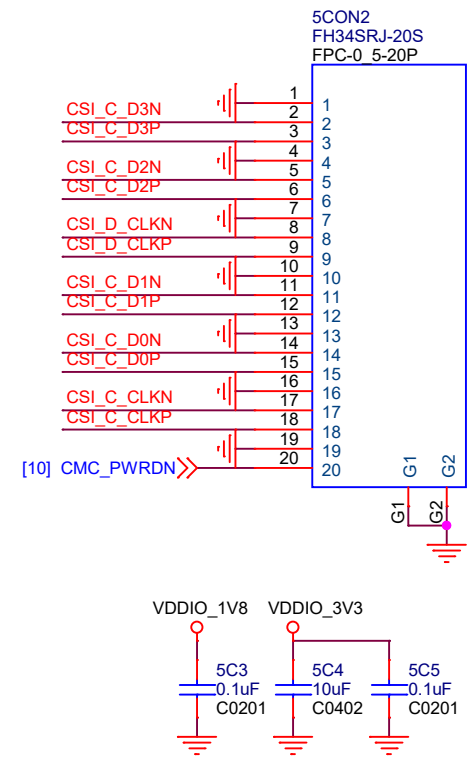

MIPI-CSI2

Shenzhen Wesion Technology Co., Ltd.			
<b>Project:</b>	VIM4		
<b>File:</b>	05 CSI CAMERA		
<b>Date:</b>	Monday, April 25, 2022	<b>Rev:</b>	V12
<b>Designed_by:</b>	Totti	<b>Sheet:</b>	5

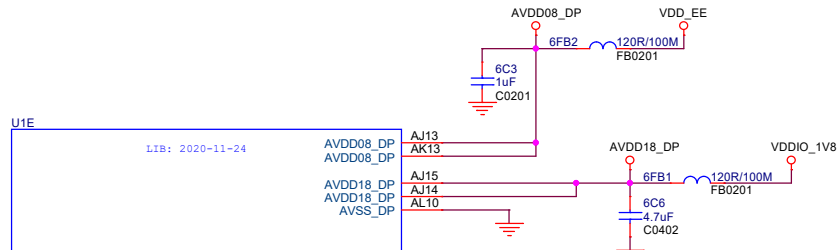

LIB: 2020-11-24

DIF_CH0(EDP_A_AUXN/DSI_A_D0N/LVDS_A_0N/IX1_A_0N)	AM18	MIPI_DSI_D0N	6TP1	1P	TP-0_5FPC_PIN
DIF_CH0(EDP_A_AUXP/DSI_A_D0P/LVDS_A_0P/IX1_A_0P)	AN18	MIPI_DSI_D0P	6TP2	1P	TP-0_5FPC_PIN
DIF_CH1(EDP_A_0N/DSI_A_D1N/LVDS_A_1N/IX1_A_1N)	AP18	MIPI_DSI_D1P	6TP3	1P	TP-0_5FPC_PIN
DIF_CH1(EDP_A_0P/DSI_A_D1P/LVDS_A_1P/IX1_A_1P)	AU19	MIPI_DSI_CLKN	6TP4	1P	TP-0_5FPC_PIN
DIF_CH2(EDP_A_1N/DSI_A_CKN/LVDS_A_2N/IX1_A_2N)	AT19	MIPI_DSI_CLKP	6TP5	1P	TP-0_5FPC_PIN
DIF_CH2(EDP_A_1P/DSI_A_CKP/LVDS_A_2P/IX1_A_2P)	AR17	MIPI_DSI_D2P	6TP6	1P	TP-0_5FPC_PIN
DIF_CH3(EDP_A_2N/DSI_A_D2N/LVDS_A_3N/IX1_A_3N)	AP17	MIPI_DSI_D2N			
DIF_CH3(EDP_A_2P/DSI_A_D2P/LVDS_A_3P/IX1_A_3P)	AU18	MIPI_DSI_D3N			
DIF_CH4(EDP_A_3N/DSI_A_D3N/LVDS_A_3N/IX1_A_4N)	AT18	MIPI_DSI_D3P			
DIF_CH4(EDP_A_3P/DSI_A_D3P/LVDS_A_3P/IX1_A_4P)					
DIF_CH5(LVDS_B_0N/IX1_A_5N)	AM15	LVDS_B_0N	6TP1	1P	TP-0_5FPC_PIN
DIF_CH5(LVDS_B_0P/IX1_A_5P)	AN15	LVDS_B_0P	6TP2	1P	TP-0_5FPC_PIN
DIF_CH6(LVDS_B_1N/IX1_A_6N)	AT17	LVDS_B_1N	6TP3	1P	TP-0_5FPC_PIN
DIF_CH6(LVDS_B_1P/IX1_A_6P)	AP16	LVDS_B_2N	6TP4	1P	TP-0_5FPC_PIN
DIF_CH7(LVDS_B_2N/IX1_A_7N)	AP15	LVDS_B_2P	6TP5	1P	TP-0_5FPC_PIN
DIF_CH7(LVDS_B_2P/IX1_A_7P)	AU16	VX1_B_D0N	6TP6	1P	TP-0_5FPC_PIN
DIF_CH8(EDP_B_AUXN/DSI_B_D0N/LVDS_B_CLKN/IX1_B_0N)	AU15	VX1_B_D0P			
DIF_CH8(EDP_B_AUXP/DSI_B_D0P/LVDS_B_CLKP/IX1_B_0P)	AR14	VX1_B_D1N			
DIF_CH9(EDP_B_0N/DSI_B_D1N/LVDS_B_3N/IX1_B_1N)	AP14	VX1_B_D1P			
DIF_CH9(EDP_B_0P/DSI_B_D1P/LVDS_B_3P/IX1_B_1P)					
DIF_CH10(EDP_B_1N/DSI_B_CKN/LVDS_C_0N/IX1_B_2N)	AT15	VX1_B_D2N			
DIF_CH10(EDP_B_1P/DSI_B_CKP/LVDS_C_0P/IX1_B_2P)	AT14	VX1_B_D2P			
DIF_CH11(EDP_B_2N/DSI_B_D2N/LVDS_C_1N/IX1_B_3N)	AT13	VX1_B_D3N			
DIF_CH11(EDP_B_2P/DSI_B_D2P/LVDS_C_1P/IX1_B_3P)	AU13	VX1_B_D3P			
DIF_CH12(EDP_B_3N/DSI_B_D3N/LVDS_C_2N/IX1_B_4N)	AN12	VX1_B_D4N			
DIF_CH12(EDP_B_3P/DSI_B_D3P/LVDS_C_2P/IX1_B_4P)	AM12	VX1_B_D4P			
DIF_CH13(LVDS_C_CLKN/IX1_B_5N)	AP12	VX1_B_D5N			
DIF_CH13(LVDS_C_CLKP/IX1_B_5P)	AR12	VX1_B_D5P			
DIF_CH14(LVDS_C_3N/IX1_B_6N)	AP11	VX1_B_D6N			
DIF_CH14(LVDS_C_3P/IX1_B_6P)	AR11	VX1_B_D6P			
DIF_CH15(VX1_B_7N)	AN11	VX1_B_D7N			
DIF_CH15(VX1_B_7P)	AN10	VX1_B_D7P			

LVDS. To support FHD, must use LVDS B and C

For all of these 4 ports eDP, MIPI DSI, LVDS, VX1, DIF\_REXT terminal resistor connecting DIF\_REXT to GND is required

VX1\_LPP VX1\_LPN VX1\_ATP

Pin VX1\_LPP, VX1\_LPN and VX1\_ATP only for Test

A311D2  
BGA\_16\_1X14\_3\_B025\_0P4

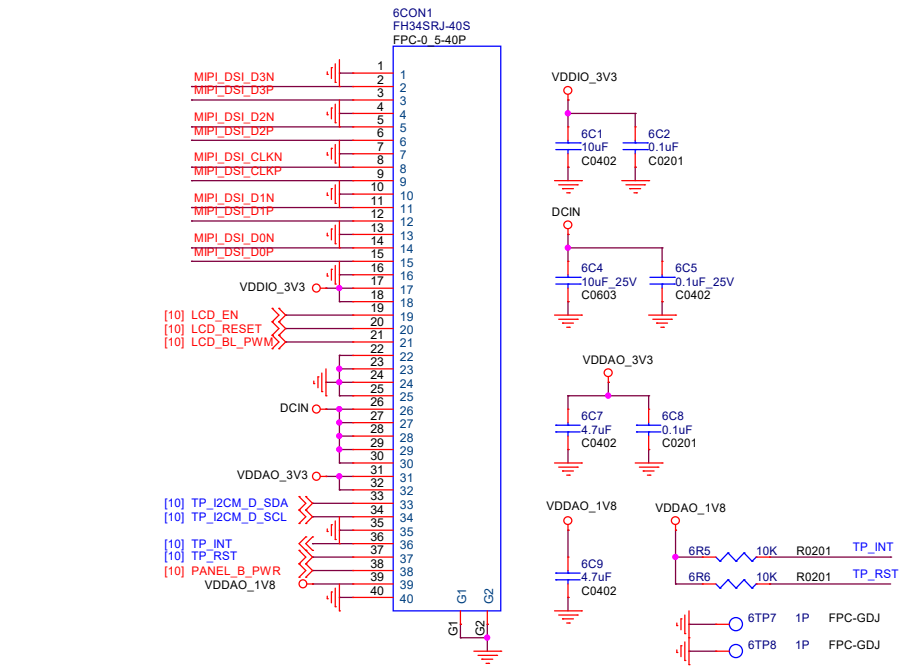

### MIPI-DSI

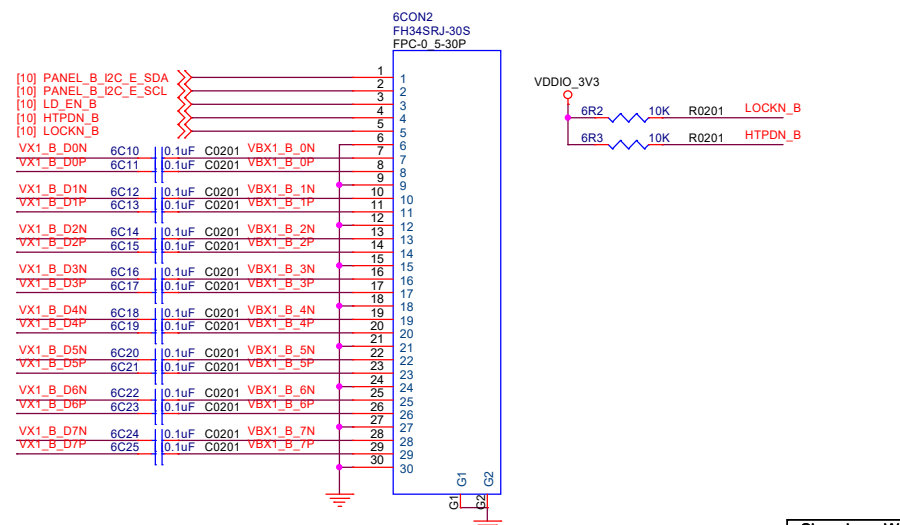

### VBO / DSI

Shenzhen Wesion Technology Co., Ltd.			
Project:	VIM4		
File:	06_DSI/eDPI/LVDS/VX1		
Date:	Monday, April 25, 2022	Rev:	V12
Designed_by:	Totti	Sheet:	6

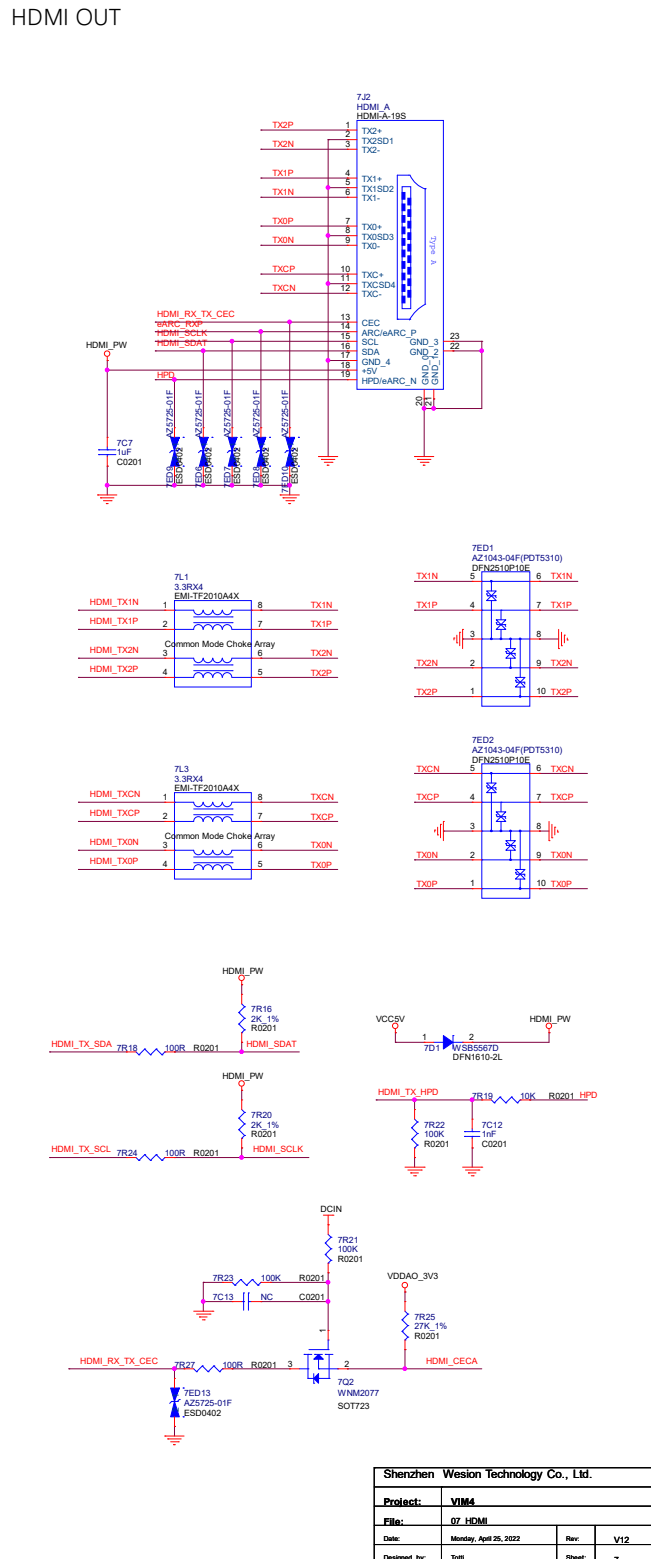
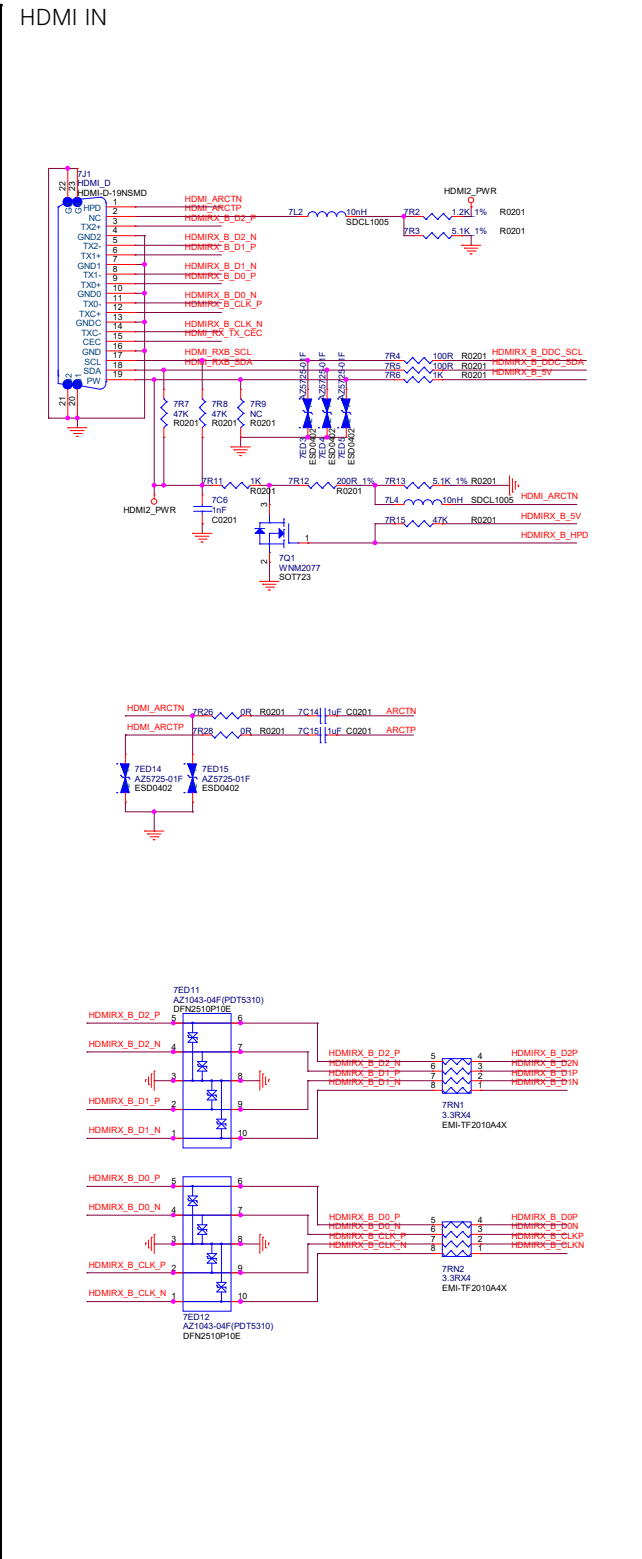
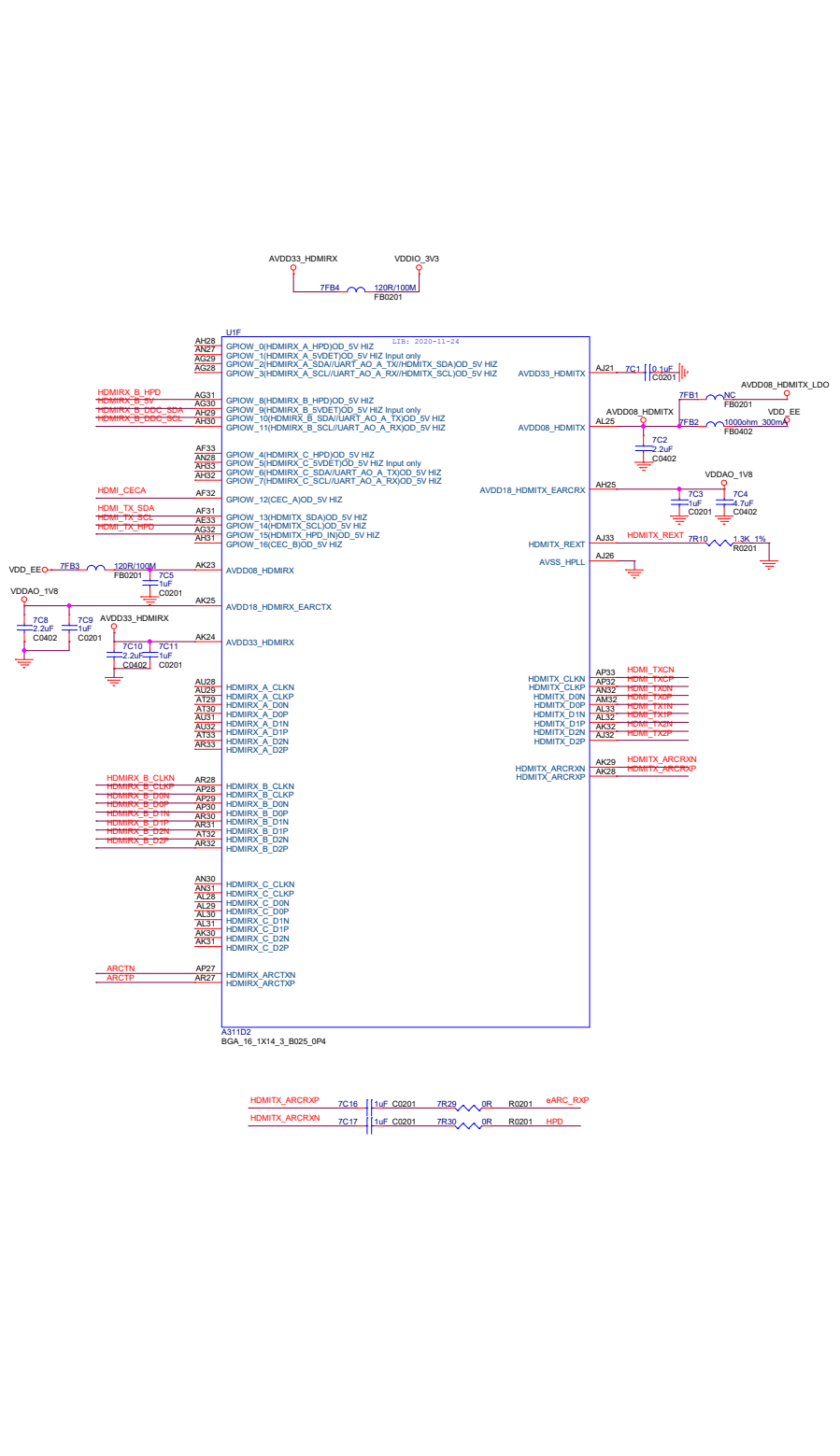





### Wi-Fi & BT

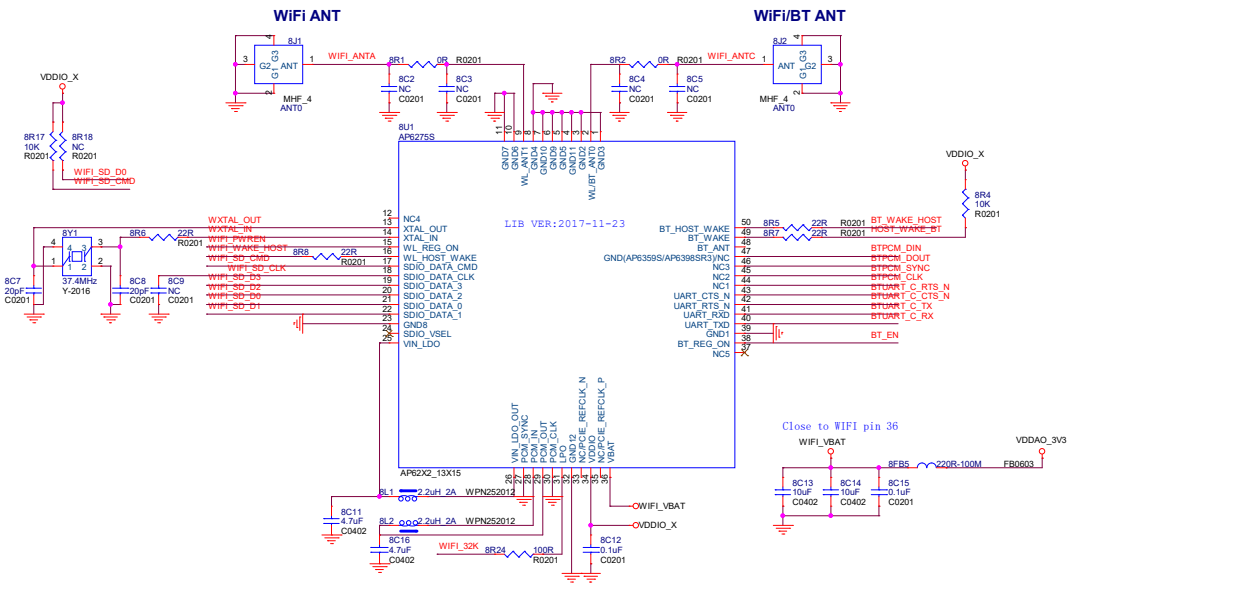

### Ethernet

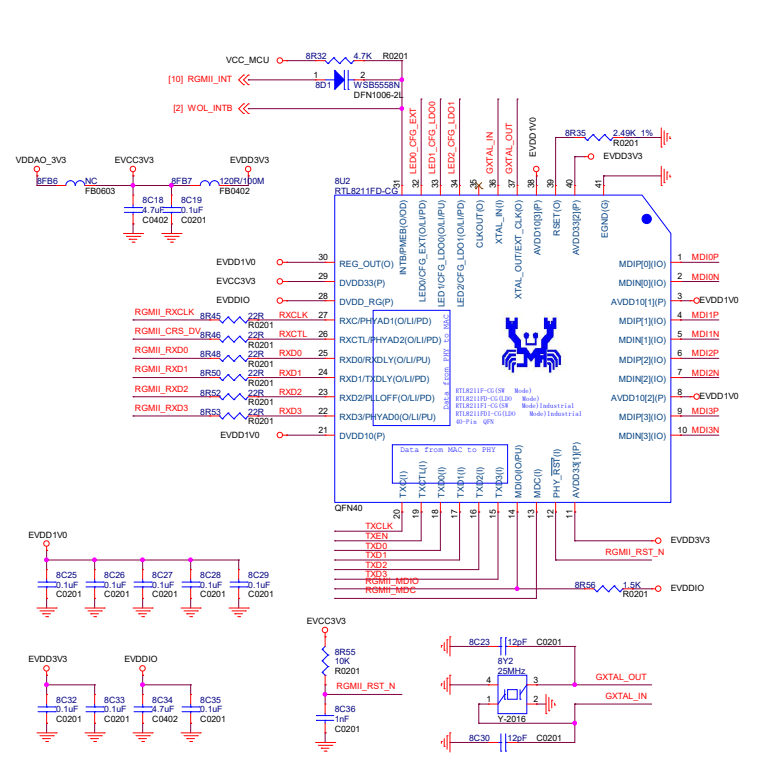

### Configuration

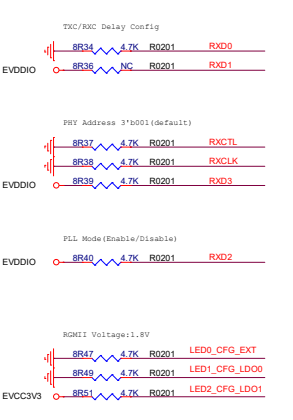

### RJ45

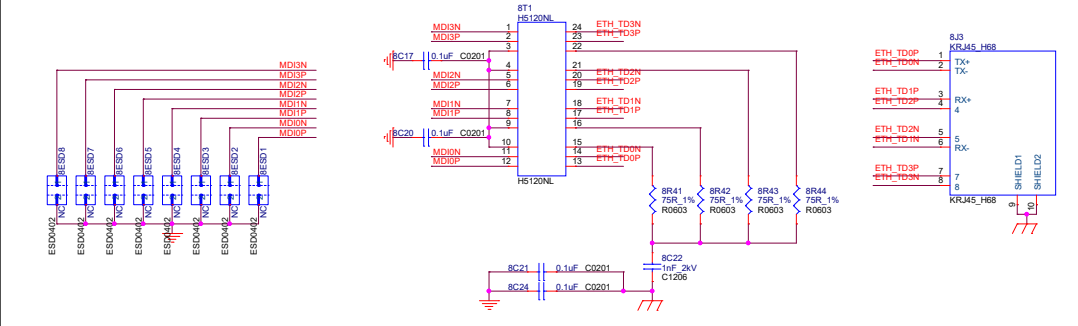

### WOL

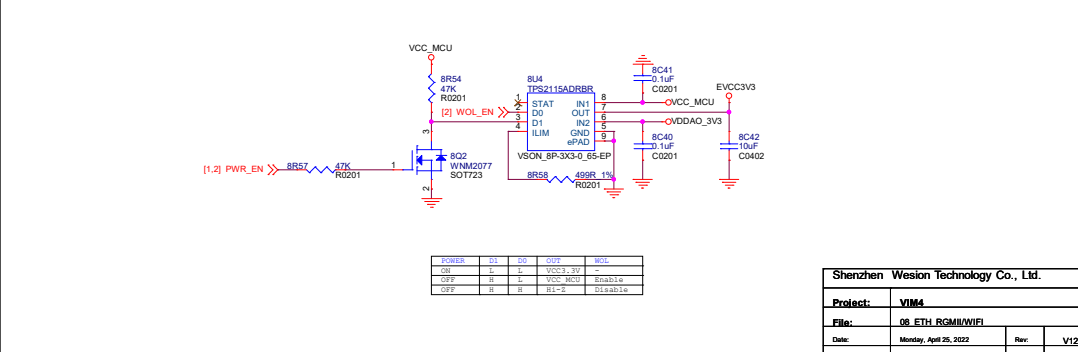

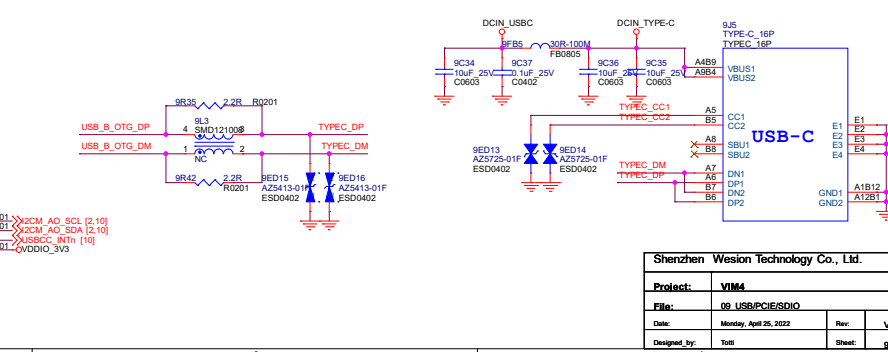
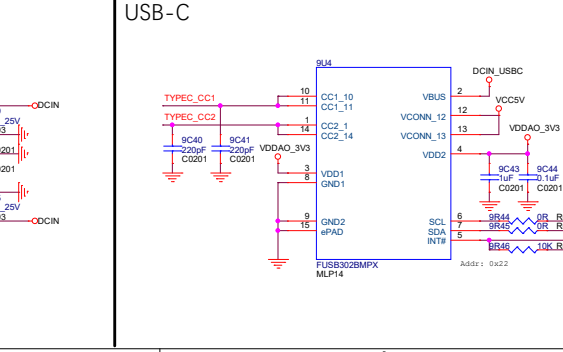
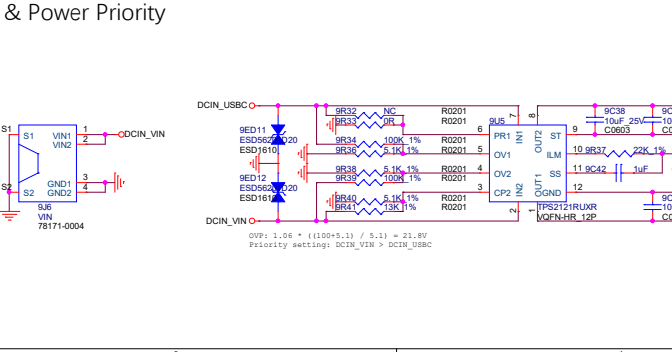
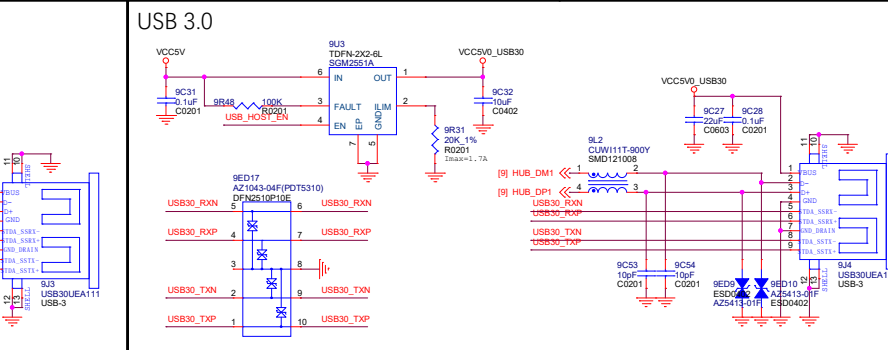
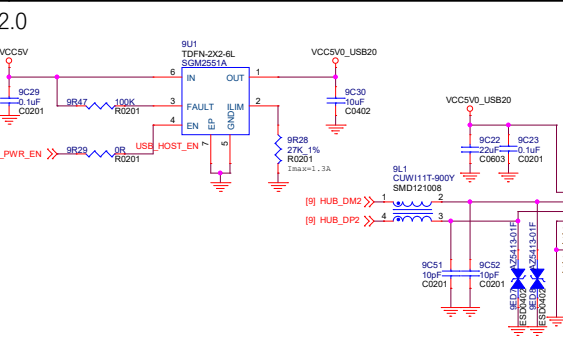
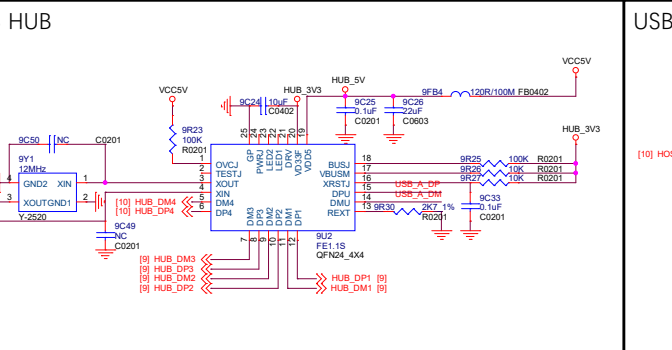
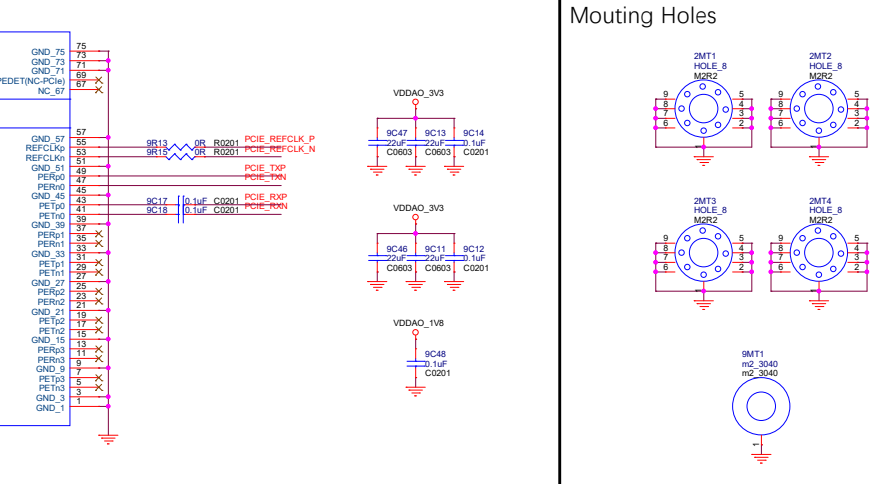
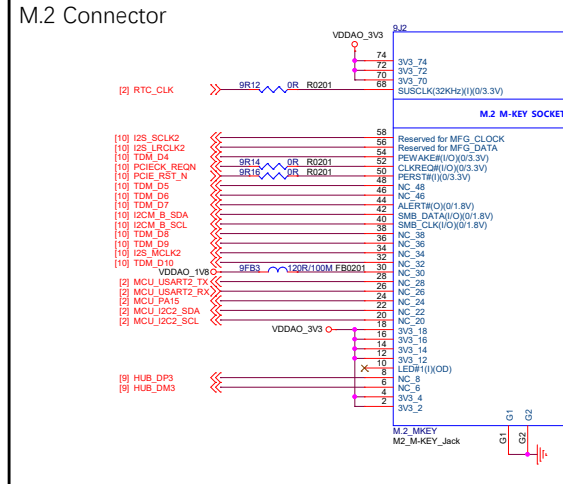
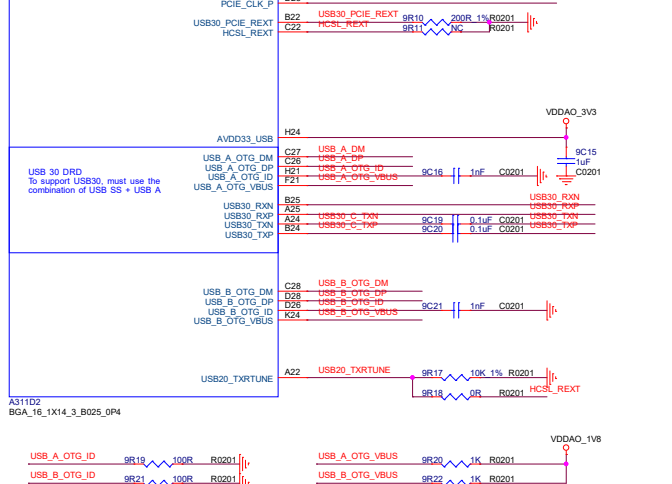
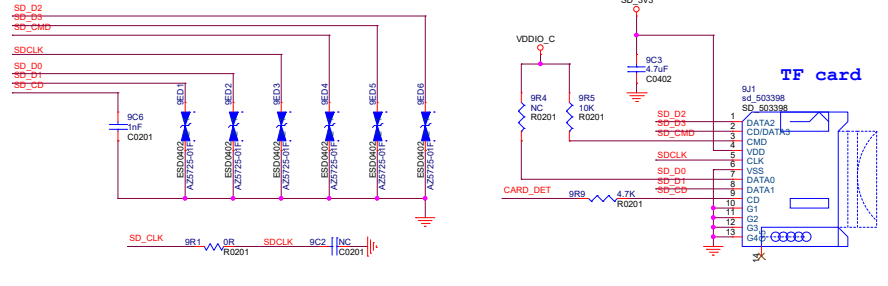
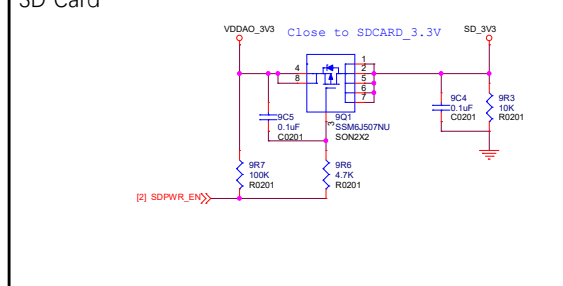
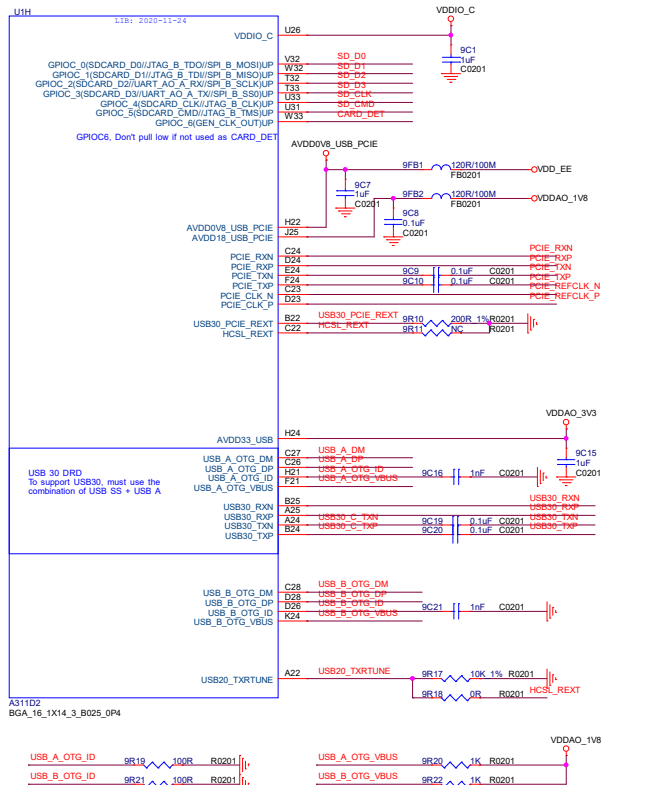

Shenzhen Weson Technology Co., Ltd.

Project:	VIM4
File:	09_USB/PCIE/SIO
Date:	Monday, April 25, 2022
Rev:	V12
Designed by:	TSS
Drawn:	g

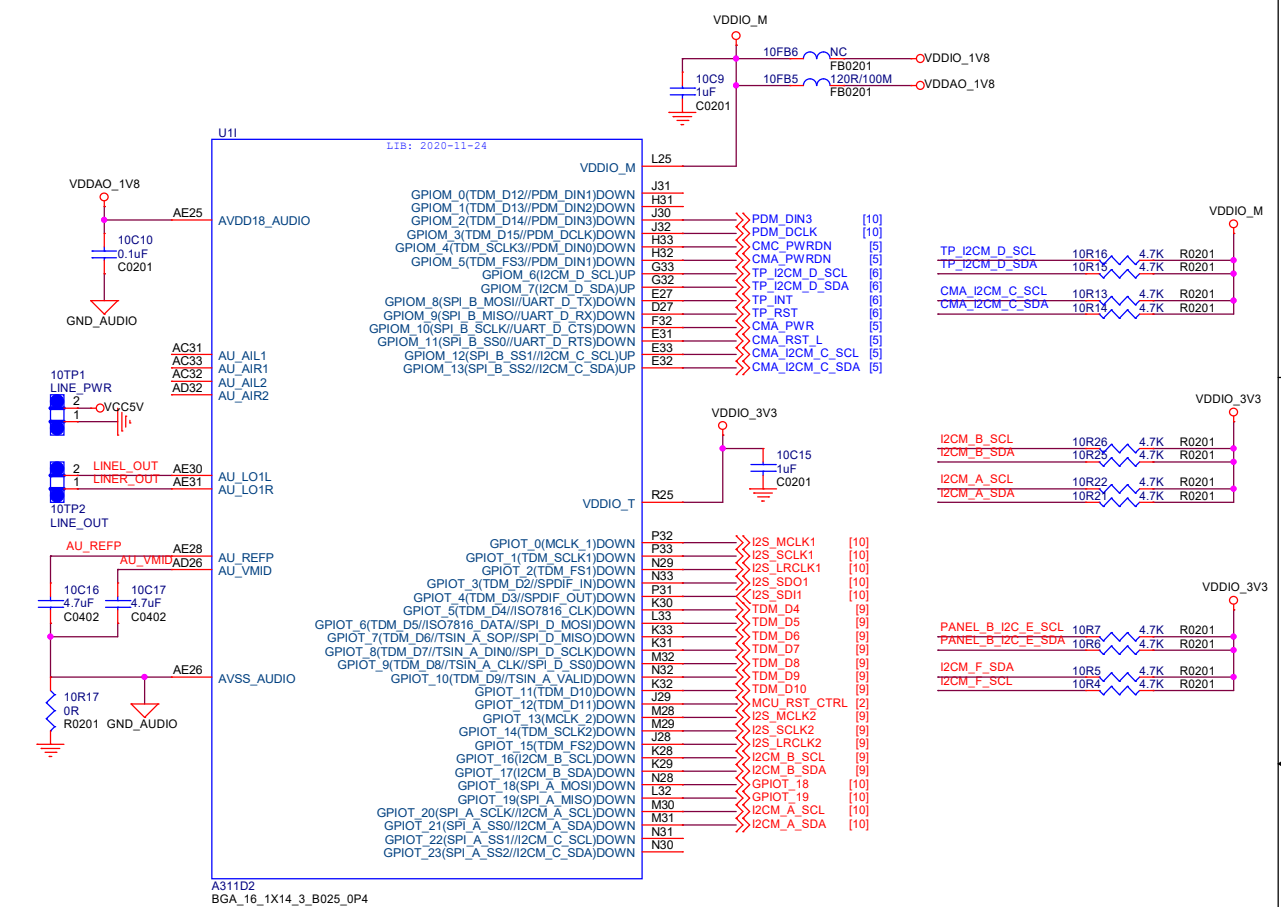
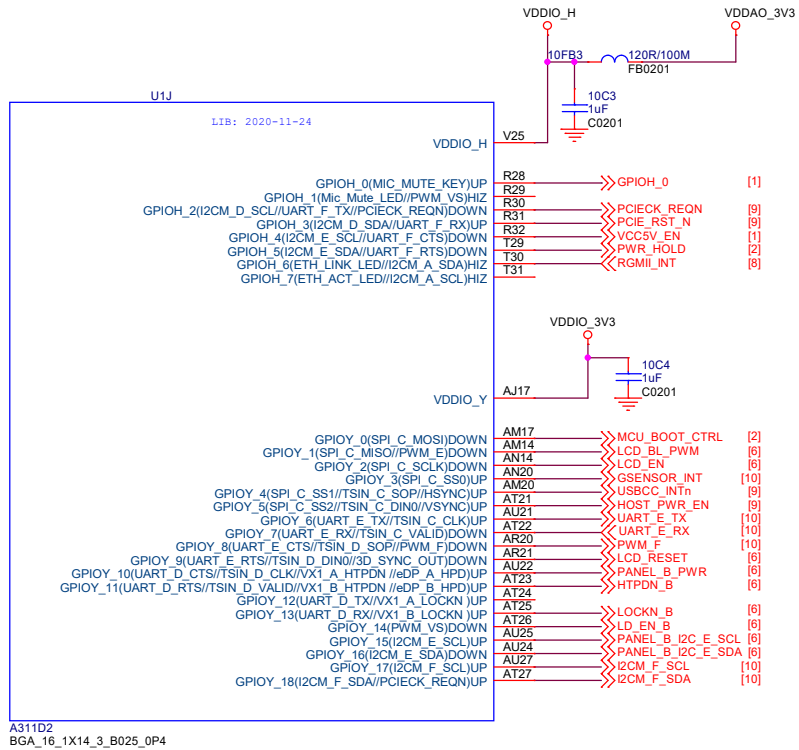

### GPIO Header

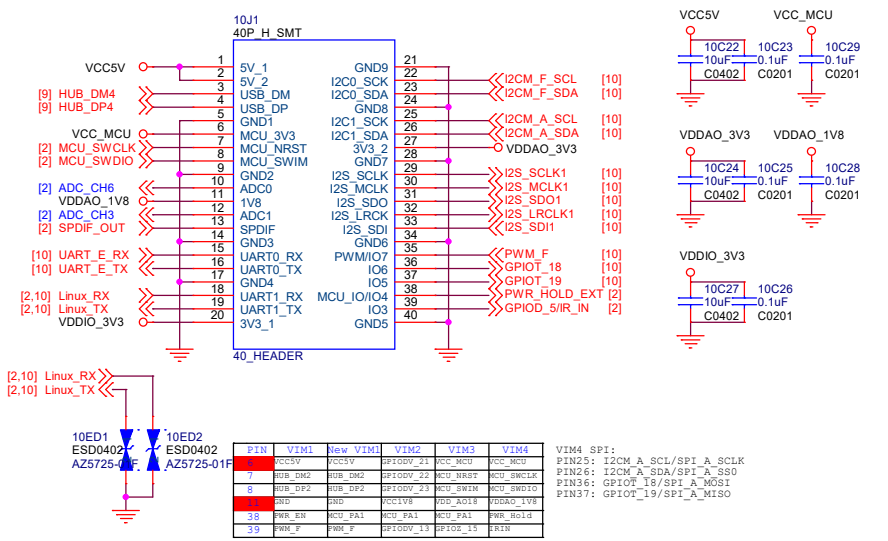

### DMIC

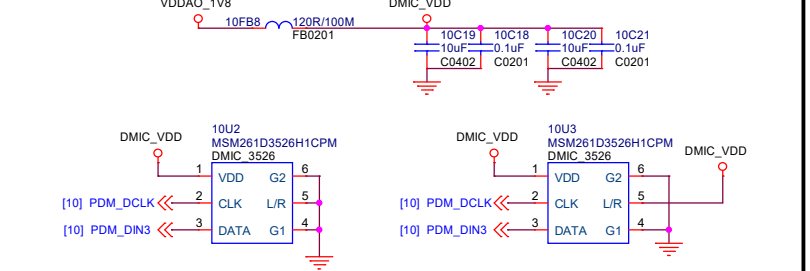

### FAN

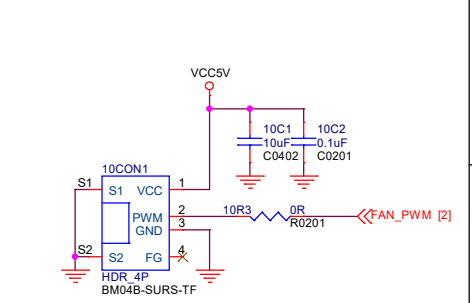

### G-sensor

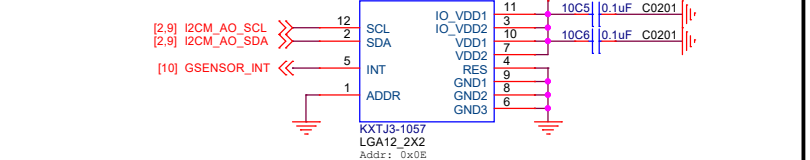

Shenzhen Wesion Technology Co., Ltd.			
Project:	VIM4		
File:	10_GPIO/FAN/Sensor/DMIC		
Date:	Monday, April 25, 2022	Rev:	V12
Designed by:	Totti	Sheet:	10

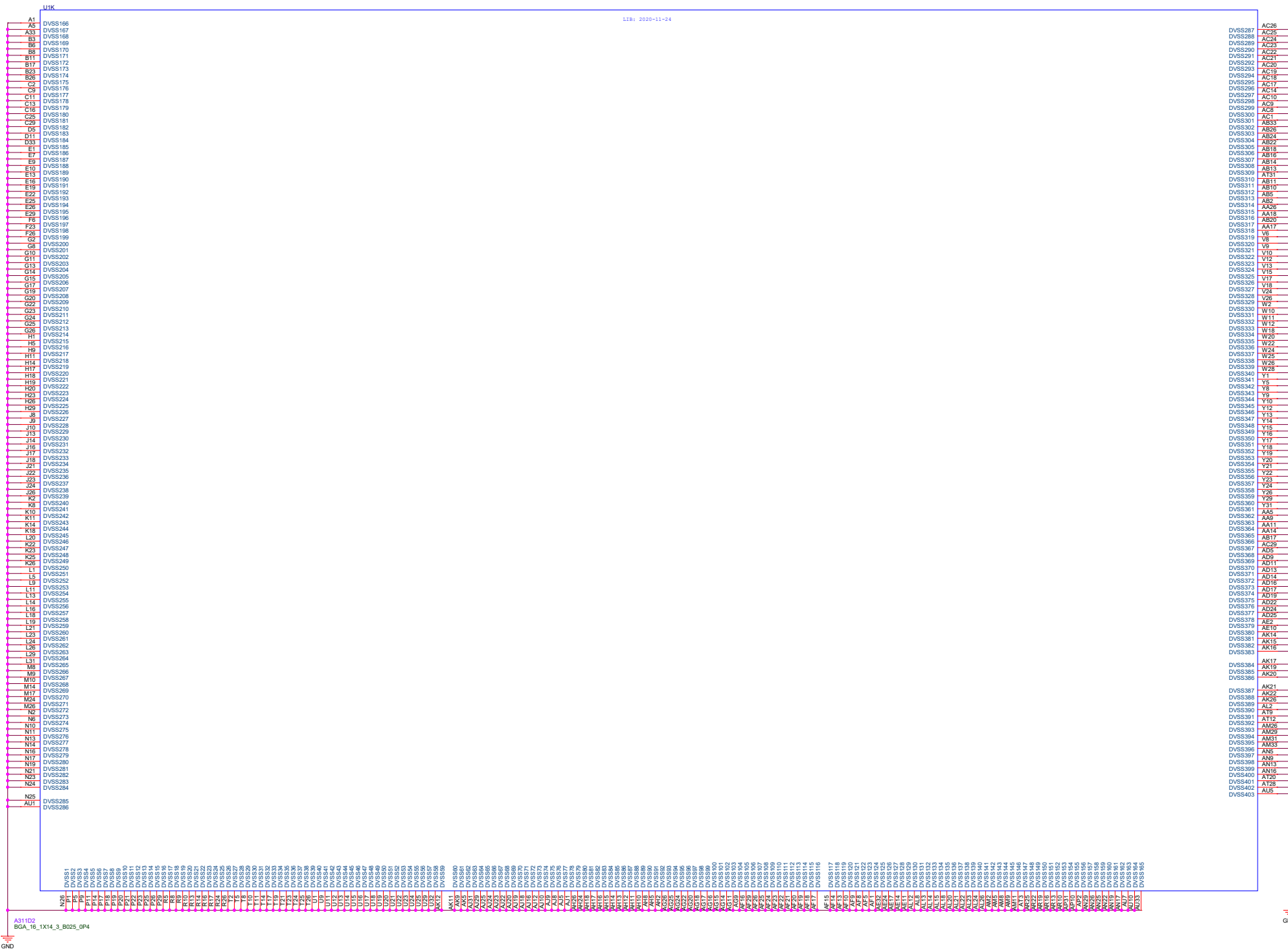

A31102  
BGA\_16\_1X14\_3\_B025\_0P4

AC26  
AC25  
AC24  
AC23  
AC22  
AC21  
AC20  
AC19  
AC18  
AC17  
AC14  
AC10  
AC9  
AC8  
AC1  
AB33  
AB26  
AB24  
AB18  
AB22  
AB16  
AB14  
AB13  
AT31  
AB11  
AB10  
AB5  
AB2  
AA18  
AA26  
AB20  
AA17  
V6  
V8  
V19  
V18  
V13  
V15  
V17  
V18  
V26  
W2  
W10  
W11  
W12  
W16  
W20  
W27  
W24  
W25  
W29  
W28  
Y1  
Y3  
Y4  
Y8  
Y10  
Y12  
Y13  
Y14  
Y15  
Y16  
Y17  
Y18  
Y19  
Y20  
Y21  
Y22  
Y23  
Y24  
Y26  
Y29  
Y31  
AA5  
AA9  
AA11  
AA14  
AA15  
AC26  
AD5  
AD9  
AD11  
AD13  
AD14  
AD16  
AD17  
AD19  
AD22  
AD24  
AD25  
AE2  
AE10  
AK14  
AK15  
AK16  
AK16  
AK17  
AK19  
AK20  
AK21  
AK22  
AK26  
AT9  
AT12  
AM26  
AM29  
AM31  
AM33  
AN6  
AN9  
AN13  
AN16  
AT20  
AT16  
AL6  
AL6

Power Tree:

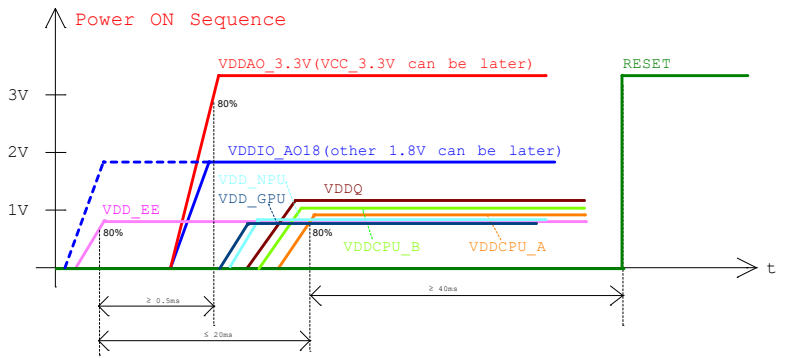
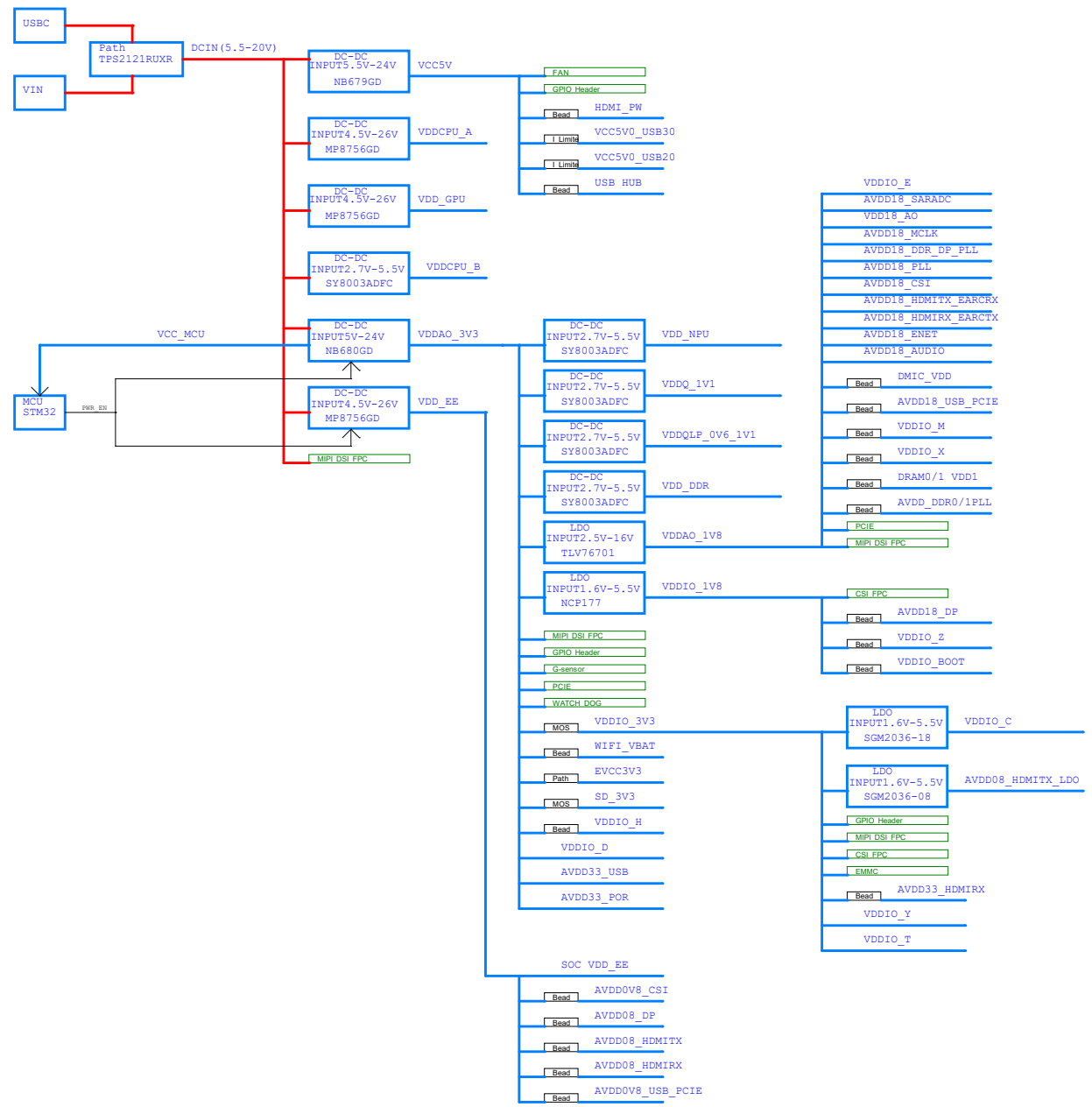

- 1) All test values refer to 80% of typical power voltage.
- 2) VDDAO\_3.3V & VCC3.3V should ramp up > 0.5ms later than VDD\_EE.
- 3) All power sources should get stable within 20ms (except VDDQ,VDD\_QLP ).
- 4) No sequence requirement between VDD18\_AO and VDD\_EE.  
No sequence requirement between VDDCPU\_A & VDDCPU\_B & VDD\_NPU & VDD\_GPU & VDDQ & VDD\_QLP & VDD\_DDR and other power source.
- 5) VDDIO\_AO18 should ramps up earlier or at the same time with VDDAO\_3.3V & VCC3.3V.
- 6) RESET\_n should keep low for at least 40ms after power up (except VDDQ,VDD\_QLP).

Power OFF Sequence

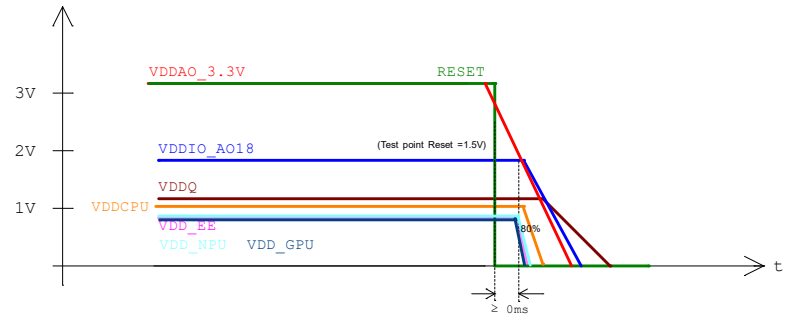

A reset IC should monitor VDDIO3.3V, output lower (lower than 1.5V) before other power rails turning off.  
There is no power off sequence requirement between other power rails.

